

IDEAL

MSC-6KLP

‘Low Profile’

Mobile Single Column Lift

6,000 lb. Capacity

(1,500 lbs. Max Capacity per Arm)



IMOBILE

Installation & Operation Manual

Sep 2022

TABLE OF CONTENTS

SAFETY INFORMATION

- Note, Caution and Warning
- Important Information
- Safety Instructions

TECHNICAL INFORMATION

- Product Description
- Specifications
- Dimensions

BEFORE USING

- Site Selection
- Surface Condition
- Operating Condition
- Main Lift Components

INSTALLATION INSTRUCTIONS

- Required Tools
- Unloading Lift
- Un-banding Lift
- Moving Lift Components
- Lift Assembly

OPERATION INSTRUCTIONS

- Lift / Vehicle Positioning, Lifting & Lowering
- Inspection, Maintenance & Cleaning
- Trouble-Shooting Guide

POWER UNIT PRIMING PROCEDURE

115V POWER UNIT ELECTRICAL DIAGRAM

EXPLODED VIEWS & PARTS LIST

LIMITED WARRANTY

SAFETY INFORMATION

Note, Caution and Warning

This document uses the following notations: Note, Caution and Warning . to alert you to special instructions, tips, or hazards for a given procedure. Please familiarize yourself with the notation explanations described below.



Indicates important information that requires special attention, such as a procedure for a specific vehicle, or tips on operating the equipment.



Indicates the potential for damage to equipment, accessories, or the vehicle unless the instructions or procedure are followed specifically.



Indicates the potential for property damage, personal injury, or death due to hazards associated with the equipment, vehicle, or environment. Do not perform any procedures until you have read and understood the warning instructions.

Important Information

1. **Read this manual thoroughly** before installing, operating, or maintaining the lift.
2. This lift is **designed for indoor use** only and **should not be positioned or operated** in a pit or depression. The lift is only to be operated on a flat level concrete surface.
3. The lift **has specific electrical requirements** as described in the Technical & Before Using sections of this manual.
4. This lift has a **minimum ceiling height & surface requirements** as described in the Before Using section of this manual.
5. Failure by the owner to provide the **recommended shelter, mounting surface, electrical supply, and ceiling height** could result in unsatisfactory lift performance, property damage or personal injury.
6. **The operation of the lift is permitted by authorized persons only.**

Safety Instructions

1. **Do not** raise a vehicle on the lift until the installation is completed as described in this manual.
2. Technicians should be trained to use and care for the lift by familiarizing themselves with the manual, including Note, Caution and Warning information. The lift should **never be operated by an untrained person**.
3. Always position the pads properly out of the way before pulling the vehicle into or out of the service bay. **Failure to do so could damage the vehicle and/or the lift.**
4. **Do not overload the lift.** The capacity of the lift is shown on cover of this manual and on the lift's serial number tag.
5. Positioning the vehicle is very important. Only trained technicians should position the vehicle on the lift. **Never allow anyone to stand in the path of the vehicle as it is being positioned and never raise vehicle with passengers inside.**
6. Position the pads to the vehicle manufacturer's recommended pickup points. Raise the lift until the pads make contact with the vehicle. Make sure the pads have properly engaged the vehicle's pick-up points before raising the lift to a working height.
7. Keep everyone clear of the lift when the lift is moving, the locking mechanism is disengaged or if the vehicle is in danger of falling.
8. Unauthorized personnel should never be in the shop area when the lift is in use.
9. Inspect the lift daily. **The lift should never be operated if it has damaged components or is malfunctioning.** Only qualified technicians should service the lift. **Replace damaged components with manufacturer's parts, or equivalent.**
10. **Keep the area around the lift clear of obstacles.**
11. **Never override the self-returning lift controls.**
12. Avoid excessive rocking of the vehicle when it is on the lift.
13. To reduce the risk of personal injury, keep hair, loose clothing, fingers, and all body parts away from moving parts.
14. To reduce the risk of electric shock, **do not** use the lift when wet, do not expose the lift to rain.
15. To reduce the risk of fire, **do not** operate equipment in the vicinity of open containers of flammable liquids (gasoline).
16. Use the lift only as described in this manual, **use only manufacturer's recommended attachments.**
17. **Unusual vehicles, such as limousines, RVs, and long wheelbase vehicles, may not be suitable for lifting on this equipment.** If necessary, consult with the manufacturer or the manufacturer's representative.
18. The maintenance procedures described in this manual can be done by the lift's owner/employer. Any other procedure should only be performed by trained lift service personnel. **These restricted procedures include, but are not limited to, the following: cylinder replacement, platform & safety latch replacement and motor replacement.**
19. Anyone who will be in the vicinity of the lift when it is in use should familiarize themselves with any Caution, Warning, and Safety related decals supplied with this lift, and replace them if they are illegible or missing.

TECHNICAL INFORMATION

Product Description

The iMOBILE MSC-6KLP 6,000 lb. Low Profile Mobile Single Column Lift is the perfect lift for limited space and situations where lift portability is more important than a floor mounted two post lift. The low profile design and drive-over ramps make drive-over vehicle loading possible, while the pallet jack feature also allows the lift to be positioned under the vehicle for loading. With a lifting height of 72+ the iMOBILE MSC-6KLP design allows access to the underside of most vehicles making it ideal for pre-service inspections or maintenance, while also providing outer vehicle access around most vehicles for wheel service repairs. Due to the unique design and portability feature, the iMOBILE MSC-6KLP is the perfect solution for a homeowner with limited space or a shop looking to improve work flow or gain additional revenue from previously unusable space.

Specifications

Specifications	MSC-6KLP
Capacity	6,000 lbs.
Width Overall	45-3/16+
Height Overall	102-3/8+
Length Overall	101-9/16+
Lift Rise Height	72+
Drive Over Base Ramp Height	3-15/16+
Swivel Pad Height - Min/Max	3-7/16+- 6-5/16+
Main Side Swing Arms - Min/Max	19-11/16+- 26+
Off Side Swing Arms - Min/Max	24-5/8+- 34+
Ship Weight	1,850 lbs.
Power	115 VAC, 1PH, 20 Amp

BEFORE USING

Site Selection

The Lift is designed for indoor use only. Application in a room with explosion hazard is not permitted. Placing the lift in a wet place, such as car wash bay, is prohibited. Ensure to check the desired location for possible obstructions such as a low ceiling, overhead lines, adequate working area, access ways and exits. Make sure to allow a minimum space of 12 to 14 feet in front and behind the Lift to accommodate all vehicles. Certain allowances should be made for special vehicle requirements or unusual floor plans.

Surface Condition

Do not use the Lift on any type of asphalt or soft surface. Ensure lift is placed on a dry, oil & grease free, level concrete surface capable of supporting the weight of the Lift with a vehicle. Do not use Lift on concrete expansion seams or cracked, defective concrete. Failure to accomplish the foundation requirement may cause lift instability, which could result in personal injury.

Operating Condition

Lift is not intended for outdoor use and has an operating ambient temperature range of 41° - 104°F (5° - 40°C).



Make sure you have made all necessary measurements to assure that your lift will fit in your shop / garage and accommodate the car you intend to lift with it. Make sure you have enough clearance at the top, and enough width to allow walking around. Also, be aware that the electrical power supply requirements are 115 volt, 1 Phase, 20 amps.

Main Lift Components

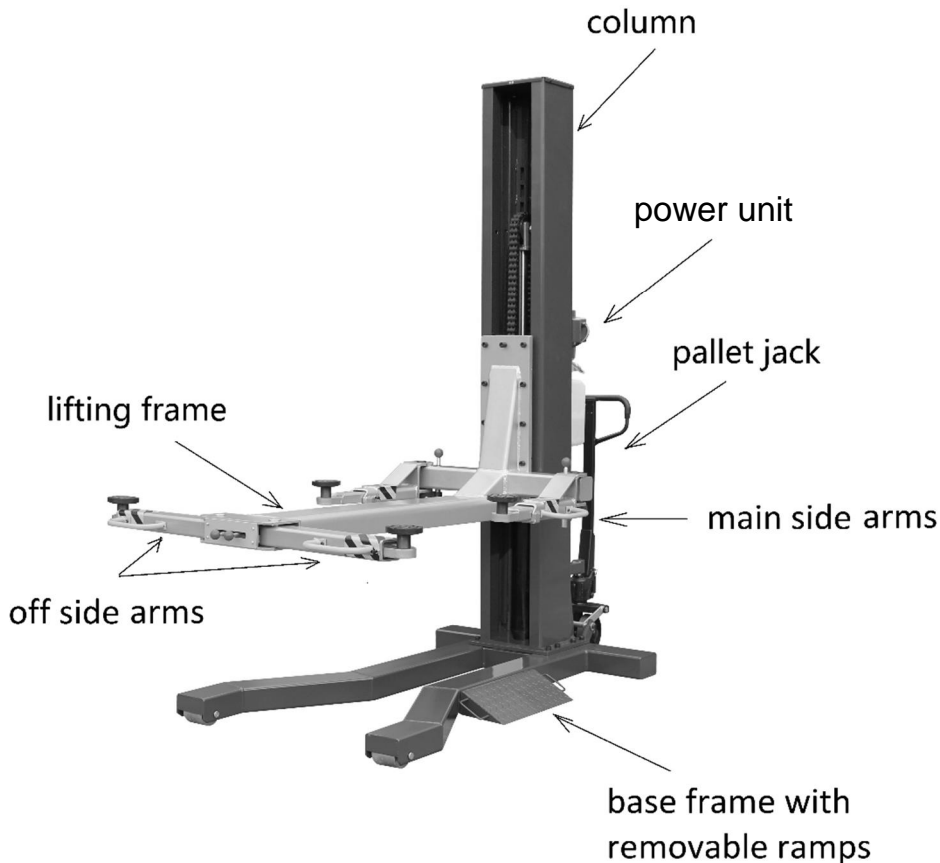

Fig. 2

INSTALLATION INSTRUCTIONS



Ensure to have someone to assist with installation, as most of the lift components are big, heavy, and cumbersome. The lift column alone weighs about 320 pounds by itself. The base frame and swing arms each will weigh 200 lbs. apiece.



It is possible for two people to install this lift if they have the appropriate lifting and handling equipment, but it is definitely easier and faster if there are several people available to help maneuver the components into place. As with any assembly involving big heavy materials, safety considerations are necessary.

Required Tools

1. Fork Lift (Offload lift package upon delivery & installation assist)
2. Fork Lift and/or Engine Hoist (Moving large components & positioning lift column)
3. Ten Foot of 3/8+Chain and/or Heavy Duty Lift Sling
4. 12mm Hex Wrench and 1/2" Socket Drive or Ratchet
5. 6mm Hex Wrench
6. 1/2+Wrench
7. 11/16+Wrench
8. Adjustable Wrench
9. Small Crowbar
10. Large Screwdriver (Aligning Bolt Holes)
11. Pliers
12. Flat Blade Screwdriver
13. Tin Snips
14. Gloves
15. Safety Glasses

Unloading the Lift



You will need a forklift that can handle about 2,000 to 2,300 pounds and operates on a smooth surface.

Un-banding the Lift



The steel bands which secure the lift parts to the pallets are heavy duty. You will need a pair of metal shears or tin snips to cut the bands. Be very careful when doing this because the bands will tend to fly apart when they are cut, and the heavy lift parts may shift when freed from the bands. Stand to the side of the bands when you cut them and use gloves when removing the cut bands because they have sharp edges.

Moving Lift Components



You can move the larger components pieces to the garage or service bay with the forklift. Some of the smaller pieces can be moved by two or more people by carrying them. If you have several people helping, some of the larger pieces can be moved manually.

Lift Assembly

STEP 1

Carefully remove shipping packaging and brackets. Remove all components & parts. Position the base plate on the ground. (Fig. 3)

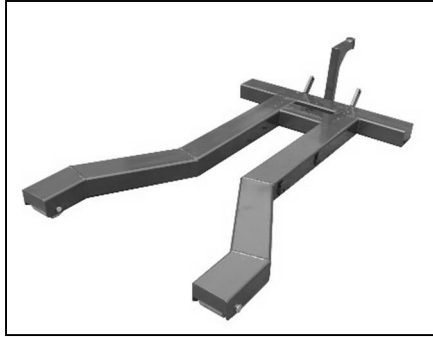

Fig. 3

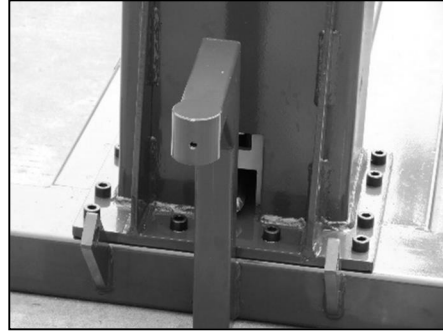

Fig. 4

STEP 2

Carefully stand the column upright, align the bolt holes and secure to base plate with bolts. (Fig.4)

STEP 3

Position the lifting frame to the front of the base plate. Then connect the lifting frame to carriage with bolts. (Fig. 5)

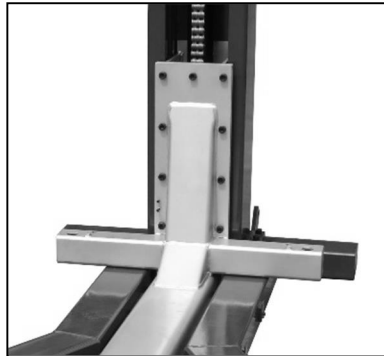

Fig. 5



Fig. 6

STEP 4

Mount the hydraulic motor pump on the column with bolts and nuts. (Fig. 6)
Connect the hose fitting and hose from pump to cylinder. (Figs. 7, 8 & 9)

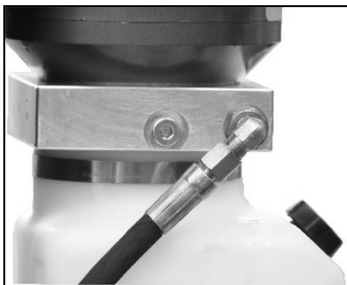

Fig. 7



Fig. 8



Fig. 9

STEP 5

Remove the lock pin on the pallet jack (Fig. 10). Place steel ball on the top of the jack ram (Fig.11)

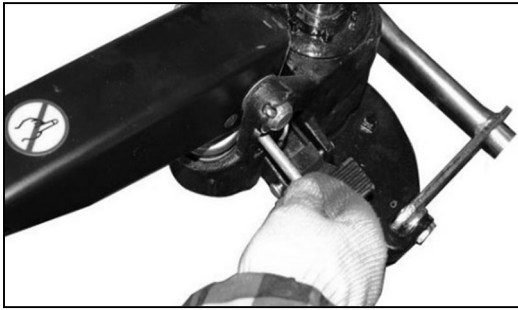

Fig. 10



Fig. 11

Insert the ram into the hole of the base plate (Fig. 12). Lock the ram by threaded pin (Fig.13). Adjust the length of the ram. (Fig. 14 & 15)

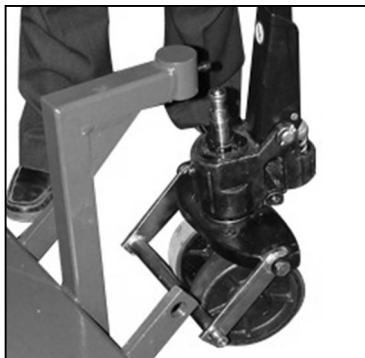

Fig. 12



Fig. 13

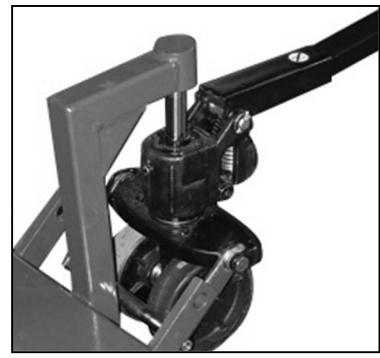

Fig.14

Put the slot of the bearing into the bracket (Fig. 16) then lock it by bolt (Fig. 17 & 18).

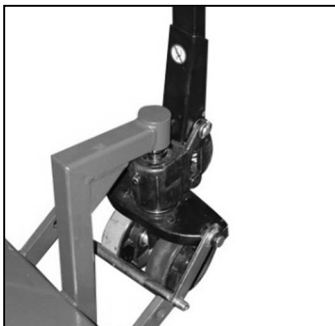

Fig. 15

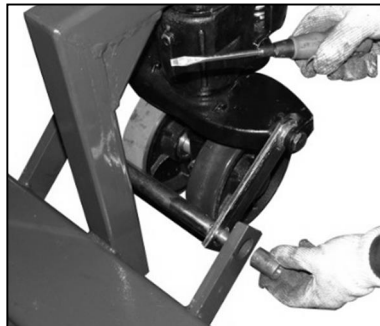

Fig. 16

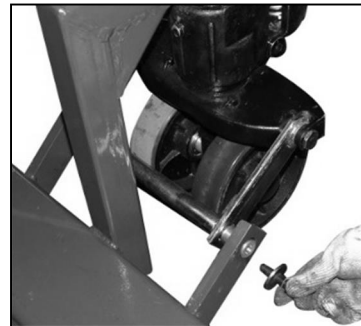

Fig. 17

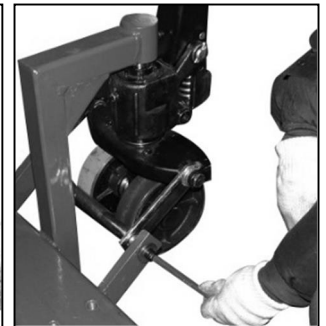

Fig. 18

The Base Plate with Pallet Jack Assembly is now Complete.

STEP 6

Locate the offside (opposite column side) arm restraint components (Fig. 19). Assemble offside arm restraints inside the lifting frame end. (Figs. 20 - 23)

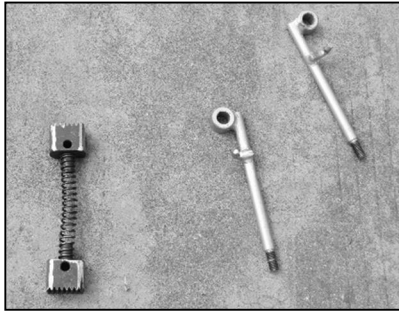

Fig. 19

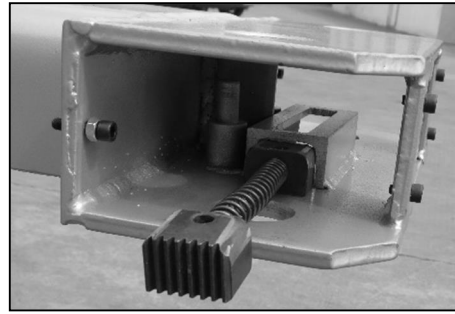

Fig. 20

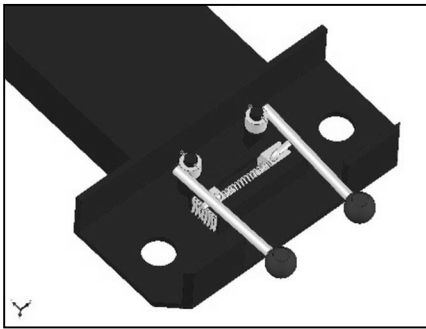

Fig. 21



Fig. 22

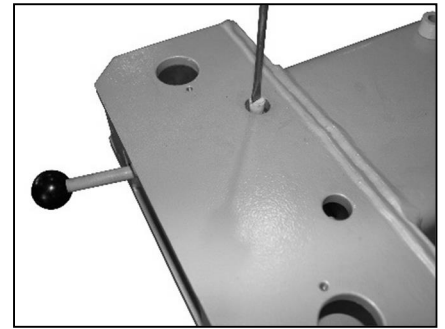

Fig. 23

STEP 7

Assemble the off side arms & handles to the end of lifting frame. (Figs. 24 & 25)



Fig. 24



Fig. 25

STEP 8

Assemble the main side arm restraints for column side & swing arms to lifting frame. (Figs 26 & 27)

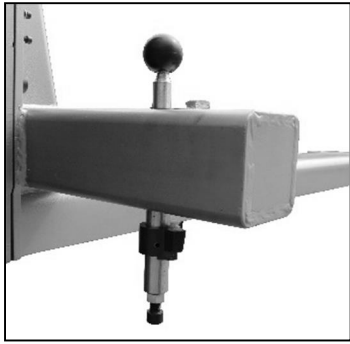

Fig. 26

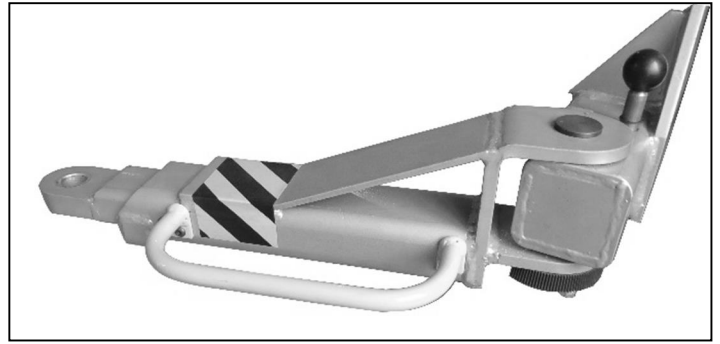

Fig. 27

STEP 9

Attach latch release cable bracket to carriage (Fig. 28). Ensure latch release cable is routed thru hole in bracket.

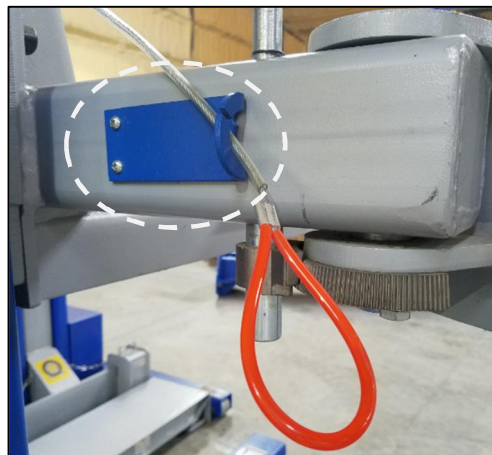

Fig. 28

STEP 10

Remove the plastic fill cap from the topside of the reservoir and fill the reservoir with approx. 12 quarts of Non-Detergent / Non-Foaming Hydraulic Oil - SAE-10, AW 32 or equivalent. Add hydraulic oil to the fill line on the front side of reservoir tank. (See Fig 29 next page)

STEP 11

Connect 115VAC electrical power to the Power Unit's three prong electrical plug. Ensure to use proper size extension cord and plug type for 20 Amps. Also ensure power supply incorporates 20 Amp breaker service for safety. If there is any question on the power source requirements, please consult an electrician.

The MSC-6KLP Lift is now ready for Operation.

(See Operation Instructions in following Pages)

OPERATION INSTRUCTIONS

To Raise, push the power switch button on the power unit and hold while it the electric motor turns on. The motor operates an internal pump that forces hydraulic oil into the lift piston, which extends the piston rod & roller chain to raise the lift. (Fig 29.)

As the lift rises, an internal safety latch will pass over the steel latch stops (rectangular blocks which protrude from the back, inside of the lift column), and you will hear clanks as it does so. This sound is normal and indicates that the safety latch is passing over the latch stops properly.

The lift is raised to the desired height by holding the switch button in while it is rising and releasing the button when the lift has reached its desired position.

For safety, it is required to release the hydraulic pressure inside the cylinder to lower the lift to nearest lower latch stop. To do this, simply press down the release handle on the power unit. Then, the lifting frame and carriage & safety latch will rest on the latch stop inside the column. (Fig 29.)

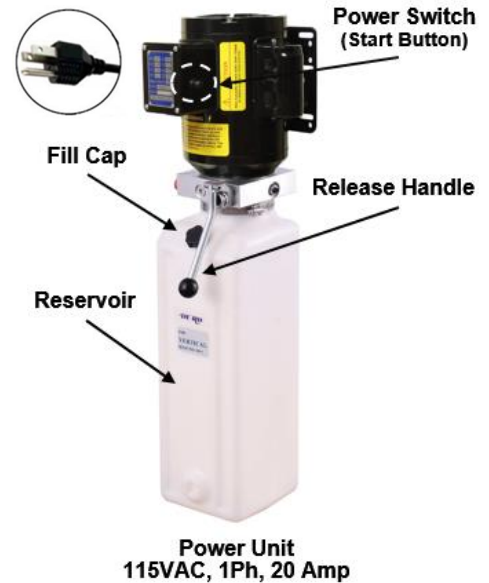

Fig. 29

To Lower, first you need to depress the power switch button a second or two to raise the lift up a little. Then, pull the safety latch release cable to disengage the safety latch to fully lower. After that press down the release handle again and hold. (Fig. 30).

The weight of the vehicle will cause the lift to lower by gravity. No power is required to be applied to the power unit while lowering, but the safety latch must be disengaged to allow the lift to lower past the latch stops.

After the installation is complete, raise the lift about two feet high and then fully lower. Repeat this process two or three times and check reservoir fluid level, while fully lowered. Only add hydraulic fluid to the reservoir & fill line, if necessary. This assures that hydraulic oil is properly distributed throughout the hydraulic system.

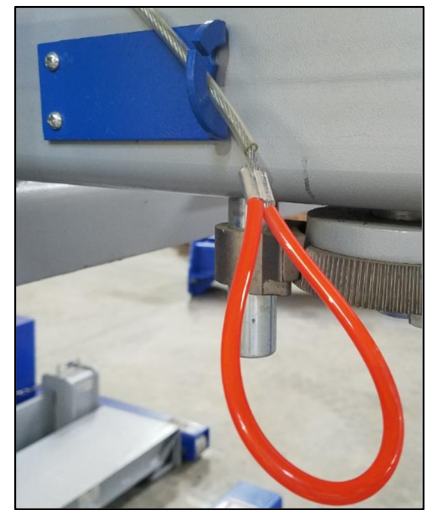

Fig. 30



Only add hydraulic fluid to the reservoir with the lift in the fully “down” position. If you fill the reservoir in the “up” position and then lower the lift, there will be too much hydraulic oil in the system and will leak out of the reservoir tank.

Lift Positioning Options

The MSC-6KLP can conveniently be positioned to raise a vehicle using two different methods:

1. DRIVING THE VEHICLE OVER THE MSC-6KLP BASE UTILIZING THE RAMPS FEATURE:

- Ensure Swing Arms are positioned to the outer positions and the Lift is positioned on a flat level surface, able to properly support the load. Carefully drive vehicle over the ramps until it is close to being centered. Set the parking brake. Position arms under the vehicle to lift at the vehicle's proper pick-up points. Once arms are positioned, spin-up the swivel pads until the rubber pads come in contact the vehicle's frame. Depress the %start+button to raise the vehicle a little and check the arms positions again to ensure the arms are in the proper position and the vehicle is properly balanced. Raise vehicle to the desired height, then lower onto latch.

2. POSITIONING THE MSC-6KLP UNDER STATIONARY VEHICLE:

- Ensure the Vehicle to be raised is positioned on a flat level surface, able to properly support being raised by the lift. Maneuver the Lift in the portable configuration to the desired side of the vehicle, ensuring the Lift is close to being centered to the vehicle. Position the Swing Arms so that the swing arms will clear the inside of both the front & back wheels, as well as the vehicle's frame. Set the parking brake and position the arms under the vehicle to lift at the vehicle's proper pick-up points. Once arms are positioned, spin-up the swivel pads until the rubber pads come in contact the vehicle's frame. Depress the %start+button to raise the vehicle a little and check the arms positions again to ensure the arms are in the proper position and the vehicle is properly balanced. Raise vehicle to the desired height, then lower onto latch.



BE CAREFUL NOT TO RAISE THE VEHICLE SO HIGH THAT IT STRIKES THE CEILING! MAKE SURE ANTENNAS ARE REMOVED, IF NECESSARY. ALSO BE AWARE OF ANYTHING THAT PROTRUDES FROM THE CEILING, LIKE LIGHT BULBS, GARAGE DOOR OPENERS OR DOOR TRACKS.

Inspection, Maintenance & Cleaning



Always unplug the Power Cord from the electrical outlet before performing any inspection, adjustments, maintenance and/or cleaning.

BEFORE EACH USE: Inspect the general condition of the Lift. Check for loose screws, misalignment or binding of moving parts, broken parts, damaged electrical wiring and hoses, and any other condition that may affect its safe operation. If abnormal noise or vibration occurs, have the problem identified and corrected before further use. **Do not use a damaged equipment.**

DAILY: With compressed air or vacuum, remove all dirt and debris from the Lift. Also, use a detergent or mild solvent to remove oil and grease from the unit. Then, use a premium quality, machine oil to lubricate all moving parts.

MONTHLY: With the lift fully lowered, check the level of hydraulic oil in the Reservoir Tank is close to the Max Fill Line. If not, remove the Fill Cap and add premium quality hydraulic oil until the level of oil is even with the Max Fill Line. After filling, place the Fill Cap to Reservoir Tank.



Never Add Hydraulic Fluid while Lift is in raised position!!



The hydraulic oil is recommended to be replaced every two years. The inside corners of the column & lift arms should be re-greased with general-purpose axle grease every year, or as becomes necessary.

Trouble-Shooting Guide

1. Motor Does Not Run:

- A. Breaker or fuse blown..... Call electrician.
- B. Faulty wiring connections..... Call electrician.
- C. Defective start button..... Call electrician.
- D. Defective capacitor..... Call electrician.

2. Motor Runs but Will Not Raise:

- A. Oil level too low..... Oil level should be at the MAX Fill Line with lift fully lowered.
- B. Check for proper clearance for the release valve & stem seat.
- C. Remove the check valve cover and clean ball and seat.
- D. A piece of trash is under the Release Valve. Push handle down and push the up button at the same time. Hold for 10-15 seconds. This should flush the valve out to remove trash.

3. Motor Runs but Will Not Raise Vehicle:

- A. Motor running on low voltage ÷ Call electrician.
- B. Lift is overloaded..... Check vehicle's gross weight.
- C. Defective pressure relief valve.

4. Oil Blows Out Power Unit Fill Cap:

- A. Oil reservoir overfilled.
- B. Lift lowered too quickly while under a heavy load.

5. Motor Hums and Will Not Run:

- A. Lift overloaded..... Remove excessive weight from lift.
- B. Bad capacitor..... Call electrician.
- C. Low voltage..... Call electrician.
- D. Faulty wiring..... Call electrician.

6. Lift Jerks Up and Down:

- A. Air in hydraulic system..... Raise lift all the way to top and return to floor. Repeat 4-6 times with intervals at least 2 minutes apart. Ensure NOT to overheat the power unit.

7. Oil Leaks:

- A. Power unit..... If the power unit leaks hydraulic oil around the tank-mounting flange, check the oil level in the tank. The fluid level should not be above the MAX Fill Line.
- B. Rod end of cylinder..... The rod seal of the cylinder is defective. Rebuild or replace the cylinder.
- C. Breather end of the cylinder..... The piston seal of the cylinder is defective. Rebuild or replace the cylinder.

8. Lift Makes Excessive Noise:

- A. Roller assemblies not moving freely..... Inspect and apply grease.
- B. Check for excessive wear on shafts & pins..... Inspect and replace.
- C. Seals are dry in hydraulic cylinder(s)..... Cycle lift up & down.

9. Lift Will Not Lower:

- A. Lock Release Cable not properly adjusted..... Inspect and adjust.
- B. Defective Release Valve..... Inspect and replace.
- C. Defective safety latch mechanism..... Inspect and replace.

POWER UNIT PRIMING PROCEDURE

THE PROBLEM: Power unit runs fine but will not pump any fluid.

Step 1 . Locate the check valve. It is the plug to the left of the lowering valve.

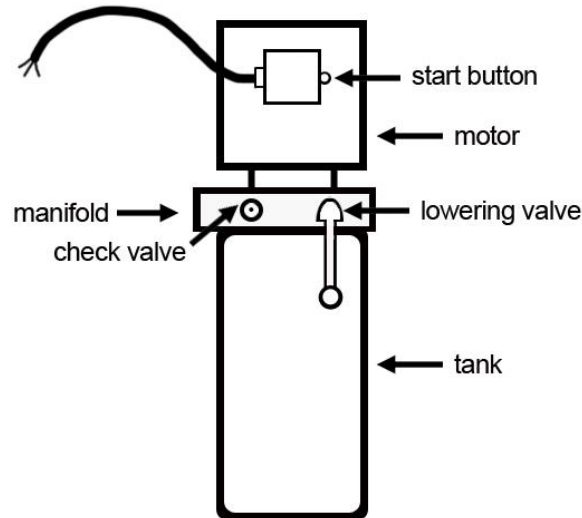

Step 2 . Using a Hex wrench and shop towel . with shop towel in place to catch fluid . loosen the check valve plug by approximately 2-½ turns and allow fluid to bleed off.

Step 3 . Push the START button for one second, then release for three seconds. Repeat these steps until unit starts pumping fluid.

Step 4 . Tighten the check valve plug.

YOUR POWER UNIT SHOULD NOW BE PRIMED, READY TO GO.

EXPLODED VIEW

(VIEW A.)

(BASE, COLUMN, POWER UNIT, PALLET JACK & CYLINDER)

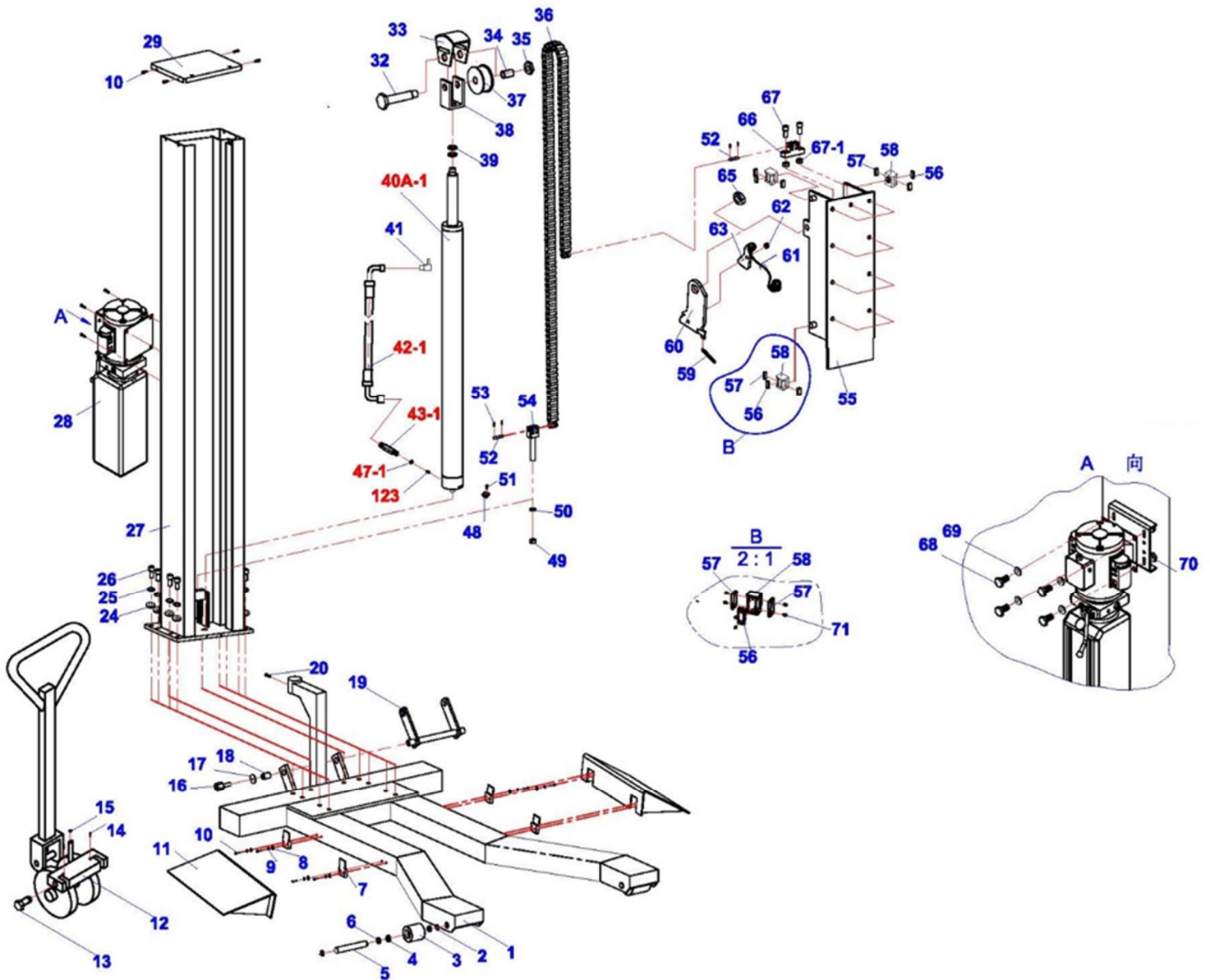

EXPLODED VIEW

(VIEW B.)

(LIFTING FRAME, ARMS, SWIVEL PADS & ADAPTORS)

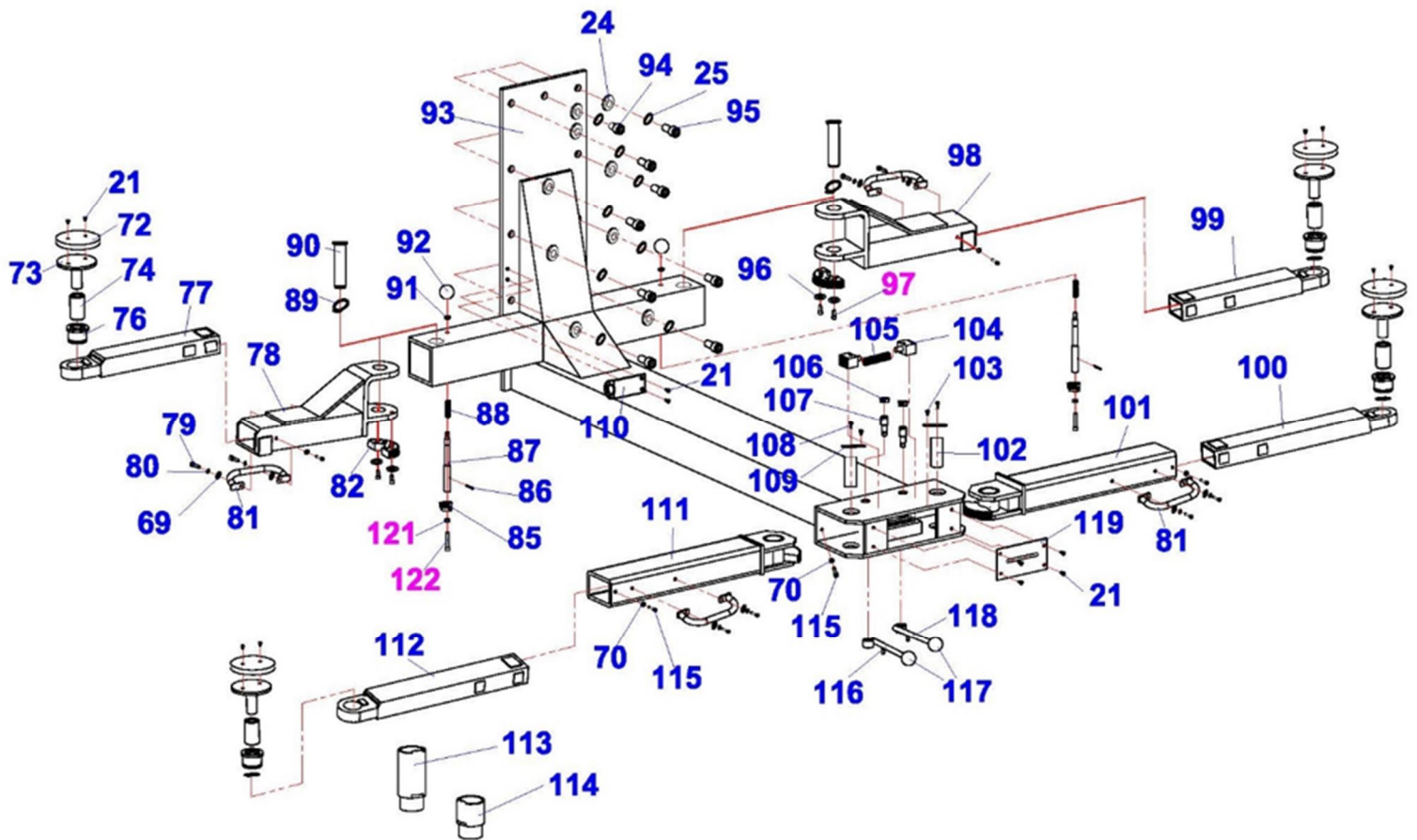

PARTS LIST

ITEM	Tux P/N	M-Ref P/N	DESCRIPTION	QTY
1	MSC-6KLP-001	DJ01-01000-M00	Base	1
2	MSC-6KLP-002	5304-00025-000	Circlip, D25	4
3	MSC-6KLP-003	DJ01-00010-M00	Roller	2
4	MSC-6KLP-004	5602-52025-000	Bearing, D52xD25x15	4
5	MSC-6KLP-005	DJ01-00011-M00	Roller Pin	2
6	MSC-6KLP-006	DJ01-00012-M00	Roller Bushing	4
7	MSC-6KLP-007	DJ01-00020-M00	Hook	4
8	MSC-6KLP-008	5301-00006-000	Flat Washer, D6	8
9	MSC-6KLP-009	5303-00006-000	Spring Washer, D6	8
10	MSC-6KLP-010	5105-06025-000	Bolt, M6x25	12
11	MSC-6KLP-011	DJ01-22000-M00	Ramp	2
12	MSC-6KLP-012	DJ01-15000-000	Pallet Jack Assy.	1
13	MSC-6KLP-013	DJ01-00018-M00	Pin	2
14	MSC-6KLP-014	5402-05030-000	Cotter Pin	2
15	MSC-6KLP-015	5601-00018-000	Ball	1
16	MSC-6KLP-016	5105-12035-000	Bolt, M12x35	2
17	MSC-6KLP-017	DJ01-00006-M00	Flat Washer	2
18	MSC-6KLP-018	DJ01-00017-M00	Spacer	2
19	MSC-6KLP-019	DJ01-17000-M00	Support Frame	1
20	MSC-6KLP-020	5105-10025-000	Bolt, M10x25	1
21	MSC-6KLP-021	5110-06012-000	Screw, M6x12	12
24	MSC-6KLP-024	5301-00016-000	Flat Washer, D16	19
25	MSC-6KLP-025	5303-00016-000	Spring Washer, D16	19
26	MSC-6KLP-026	5105-16050-000	Bolt, M16x50	10
27	MSC-6KLP-027	DJ01-02000-M00	Column	1
28	PU-110V-L-K	PU-110V-L-K	DURO Power Unit 110-115VAC	1
29	MSC-6KLP-029	DJ01-00005-M00	Top Plate	1
32	MSC-6KLP-032	DJ01-00015-M00	Spindle	1
33	MSC-6KLP-033	DJ01-19000-M00	Roller Bearing Cover	1
34	MSC-6KLP-034	DJ01-00032-M00	Bearing, D30x2	1
35	MSC-6KLP-035	5206-00024-000	Nut, M24	1
36	MSC-6KLP-036	DJ01-00007-M00	Chain	1
37	MSC-6KLP-037	DJ01-00014-M00	Roller Bearing	1
38	MSC-6KLP-038	DJ01-20000-M00	Roller Seat	1
39	MSC-6KLP-039	DJ01-00013-M00	Nut, M27	2
40A-1	MSC-6KLP-040A.1	DJ01-21000-M00-A-1	*Hydraulic Cylinder	1
41	MSC-6KLP-041	SJ01-12001-000	90 degree Fitting	1
42-1	MSC-6KLP-042.1	DJ01-00021-M00-1	*Hydraulic Hose	1
43-1	MSC-6KLP-043.1	DJ01-00031-M00-1	*Straight Fitting	1
47-1	MSC-6KLP-047.1	5603-00016-000-1	*Seal Ring, D14	1
48	MSC-6KLP-048	DJ02-00027-000	Cylinder Key Tab	1

49	MSC-6KLP-049	5206-00020-000	Lock Nut, M20	1
50	MSC-6KLP-050	5201-00020-000	Nut, M20	1
51	MSC-6KLP-051	5101-08030-000	Bolt, M8x30	1
52	MSC-6KLP-052	DJ01-00004-M00	Chain Pin	2
53	MSC-6KLP-053	5404-03020-000	Split Pin, D3x20	4
54	MSC-6KLP-054	DJ01-00003-M00	Upper Chain Block	1
55	MSC-6KLP-055	DJ01-12000-M00	Carriage	1
56	MSC-6KLP-056	DJ01-00029-M00	Top, Sliding Block	4
57	MSC-6KLP-057	DJ01-00028-M00	Side, Sliding Block	8
58	MSC-6KLP-058	DJ01-00027-M00	Sliding Block Frame	4
59	MSC-6KLP-059	SJ01-07007-000	Spring	1
60	MSC-6KLP-060	DJ01-13001-M00	Safety Latch	1
61	MSC-6KLP-061	DJ01-13003-M00	Steel Rod	1
62	MSC-6KLP-062	5206-00010-000	Lock Nut, M10	1
63	MSC-6KLP-063	DJ01-13002-M00	Latch Cam	1
65	MSC-6KLP-065	5206-00030-000	Lock Nut M30	1
66	MSC-6KLP-066	DJ01-00001-M00	Lower Chain Block	1
67	MSC-6KLP-067	5105-16060-000	Bolt, M16x60	2
67-1	MSC-6KLP-067.1	5206-00016-000	Lock Nut, M16	2
68	MSC-6KLP-068	5101-08025-000	Bolt, M8x25	4
69	MSC-6KLP-069	5301-00008-000	Flat Washer, D8	16
70	MSC-6KLP-070	5201-00008-000	Nut, M8	10
71	MSC-6KLP-071	5110-04010-000	Screw, M4x10	24
72	MSC-6KLP-072	SJ03-00008-000	Rubber Pad	4
73	MSC-6KLP-073	SJ12-10100-A00	Swivel Pad	4
74	MSC-6KLP-074	SJ12-10002-A00	Threaded Adaptor-Long	4
76	MSC-6KLP-076	SJ12-10001-A00	Threaded Adaptor-Short	4
77	MSC-6KLP-077	DJ01-06000-M00	LH, MS Arm Extension	1
78	MSC-6KLP-078	DJ01-04000-M00	LH, Mainside Arm	1
79	MSC-6KLP-079	5118-08012-000	Screw, M8x12	8
80	MSC-6KLP-080	5303-00008-000	Spring Washer D10	8
81	MSC-6KLP-081	DJ01-18000-M00	Handle, Swing Arm	4
82	MSC-6KLP-082	SJ01-00025-000	Large Gear	2
85	MSC-6KLP-085	SJ01-00023-000	Small Gear	2
86	MSC-6KLP-086	5402-06038-000	Cotter Pin, D6x38	2
87	MSC-6KLP-087	DJ01-00009-M00	Gear Pin, Small	2
88	MSC-6KLP-088	DJ01-00002-M00	Spring, Gear Pin	2
89	MSC-6KLP-089	5304-00038-000	Circlip, D38	2
90	MSC-6KLP-090	DJ01-00025-M00	MS, Swing Arm Pin	2
91	MSC-6KLP-091	5304-00018-000	Circlip, D18	2
92	MSC-6KLP-092	SJ03-00013-000	Pull Knob	2
93	MSC-6KLP-093	DJ01-03000-M00	Lifting Frame	1
94	MSC-6KLP-094	5105-16025-000	Bolt, M16x25	1
95	MSC-6KLP-095	5105-16040-000	Bolt, M16x40	8

96	MSC-6KLP-096	5301-00010-000	Flat Washer, D10	4
97	MSC-6KLP-097	5101-10035-000	Bolt, M10x35	4
98	MSC-6KLP-098	DJ01-05000-M00	RH, Mainside Arm	1
99	MSC-6KLP-099	DJ01-07000-M00	RH, MS Arm Extension	1
100	MSC-6KLP-100	DJ01-11000-M00	RH, OS Arm Extension	1
101	MSC-6KLP-101	DJ01-09000-M00	RH, Offside Arm	1
102	MSC-6KLP-102	DJ01-16002-M00	OS, Swing Arm Pin	2
103	MSC-6KLP-103	5107-06012-000	Screw, M6x12	2
104	MSC-6KLP-104	DJ01-00024-M00	Gear Block	2
105	MSC-6KLP-105	DJ01-00023-M00	Spring	2
106	MSC-6KLP-106	DJ01-00036-M00	Cap Bolt	2
107	MSC-6KLP-107	DJ01-00035-M00	Fixing Pin	2
108	MSC-6KLP-108	5107-08020-000	Screw, M8x20	2
109	MSC-6KLP-109	DJ01-16001-M00	Plate, Fixing Pin	2
110	MSC-6KLP-110	DJ01-00008-M00	Bracket, Release Cable	1
111	MSC-6KLP-111	DJ01-08000-M00	LH, Offside Arm	1
112	MSC-6KLP-112	DJ01-10000-M00	LH, OS Arm Extension	1
113	MSC-6KLP-113	SJ12-00019-A00	Pad Extension - 4"	4
114	MSC-6KLP-114	SJ12-00018-A00	Pad Extension - 2"	4
115	MSC-6KLP-115	5105-08025-000	Bolt, M8x25	6
116	MSC-6KLP-116	DJ01-14000-M00	LH, Release Handle	1
117	MSC-6KLP-117	DJ01-00026-M00	Handle Ball	2
118	MSC-6KLP-118	DJ01-15000-M00	RH, Release Handle	1
119	MSC-6KLP-119	DJ01-00019-M00	Slotted Cover Plate	1
121	MSC-6KLP-121	5101-12035-000	*Bolt, M12x35	2
122	MSC-6KLP-122	5205-00012-000	*Thin Nut, M12	2
123	MSC-6KLP-123	DJ01-00040-M00	*Compensate Valve, FR8	1

LIMITED WARRANTY

Structural Warranty:

The following parts and structural components carry a five year warranty:

Columns	Arms	Uprights	Swivel Pins
Legs	Carriages	Overhead Beam	
Tracks	Cross Rails	Top Rail Beam	

Limited One-Year Warranty:

Tuxedo Distributors, LLC (iDEAL) offers a limited one-year warranty to the original purchaser of Lifts and Wheel Service equipment in the United States and Canada. Tuxedo will replace, without charge, any part found defective in materials or workmanship under normal use, for a period of one year after purchase. The purchaser is responsible for all shipping charges. This warranty does not apply to equipment that has been improperly installed or altered or that has not been operated or maintained according to specifications.

Other Limitations:

This warranty does not cover:

1. Parts needed for normal maintenance
2. Wear parts, including but not limited to cables, slider blocks, chains, rubber pads and pulleys
3. Replacement of lift and tire changer cylinders after the first 30 days. A seal kit and installation instructions will be sent for repairs thereafter.
4. On-site labor

Upon receipt, the customer must visually inspect the equipment for any potential freight damage before signing clear on the shipping receipt. Freight damage is not considered a warranty issue and therefore must be noted for any potential recovery with the shipping company.

The customer is required to notify Tuxedo of any missing parts within 72 hours. Timely notification must be received to be covered under warranty.

Tuxedo will replace any defective part under warranty at no charge as soon as such parts become available from the manufacturer. No guarantee is given as to the immediate availability of replacement parts.

Tuxedo reserves the right to make improvements and/or design changes to its lifts without any obligation to previously sold, assembled, or fabricated equipment.

There is no other express warranty on the Tuxedo lifts and this warranty is exclusive of and in lieu of all other warranties, expressed or implied, including all warranties of merchantability and fitness for a particular purpose.

To the fullest extent allowed by law, Tuxedo shall not be liable for loss of use, cost of cover, lost profits, inconvenience, lost time, commercial loss or other incidental or consequential damages.

This Limited Warranty is granted to the original purchaser only and is not transferable or assignable.

Some states do not allow exclusion or limitation of consequential damages or how long an implied warranty lasts, so the above limitations and exclusions may not apply. This warranty gives you specific legal rights and you may have other rights, which may vary from state to state.

8320 E Hwy 67, Alvarado, TX 76009
Ph. 817-558-9337 / Fax 817-558-9740